



SoundWater Orcas™ Fluid flow sensing, redefined

Portable Transit Time Ultrasonic Flowmeter

Instruction Guide
For Orcas Mini, Orcas Standard
and Orcas Extended

Contents

General Information	Page
General Information	3
Meter Features	3
Specifications	4
Dimensions	4
App Features	5
Technology	5
Do's and Don'ts	5
App Installation	
Getting Started	6
Location Setup	6
Parameter Setup	7
Flowmeter Installation	
Straight Pipe Recommendations	8
Full Pipe Recommendations	9
Flowmeter Orientation	9
Transducer Spacing	10
Power Considerations	10
Installing the Flowmeter	11
Operation	
Collecting Your Data	12
Data Logging	12
Troubleshooting	
Problems	15
Probable Causes	15
Things to Try	15

This device complies with Part 15 of FCC Rules and Industry Canada license-exempt RSS standard(s). Operation is subject to the following two conditions: [1] this device may not cause harmful interference, and [2] this device must accept any interference received, including interference that may cause undesired operation. Contains FCC ID: XDULE40-S2, Contains IC: 8456A-LE4S2. CAN ICES-1/NMB-1; CAN ICES-3 [B]/NMB-3[B]

MODEL: SWT ORCAS-01

General Information

Meet Orcas. Now you can capture accurate and reliable flow readings with your mobile device, with less hassle and in less time—wherever you need a flow or volume measurement.

No wires. No bulky electronics box to lug around. Your ultrasonic sensor hardware installs on the outside of your pipe in a snap—and senses through the pipe wall. Your mobile device displays readings and helps you set up the hardware.

The Orcas Flowmeter solution starts with the Orcas App [downloadable from the app stores] and works on both iOS™ and Android™ devices.

The Orcas Flowmeter is a compact, strap-on transit time ultrasonic transducer device. The Orcas operates by alternately transmitting and receiving a burst of sound energy between two transducers. It then wirelessly

transmits flow measurements to your mobile device. Use the portable data logger to conveniently record flow for as long as 14 days or as little as one minute.

Orcas is highly portable. Just bring the rechargeable clamp-on meter in its lightweight, weatherproof case, along with a tablet or smartphone (iOS or Android). Bluetooth connectivity replaces wires, and the Orcas App guides you through setup.

The convenient cam cleats let you mount the flowmeter on any pipe in seconds—no cumbersome clamps required.

Bi-directional readings are transmitted to your mobile device for display and your location's settings are stored in the Orcas App, ready for reuse.

When you are done, simply release the cleats, then take the compact meter on to your next location.

Meter Features

All Orcas models including the Orcas Mini, Standard and Extended include the same features shown below.

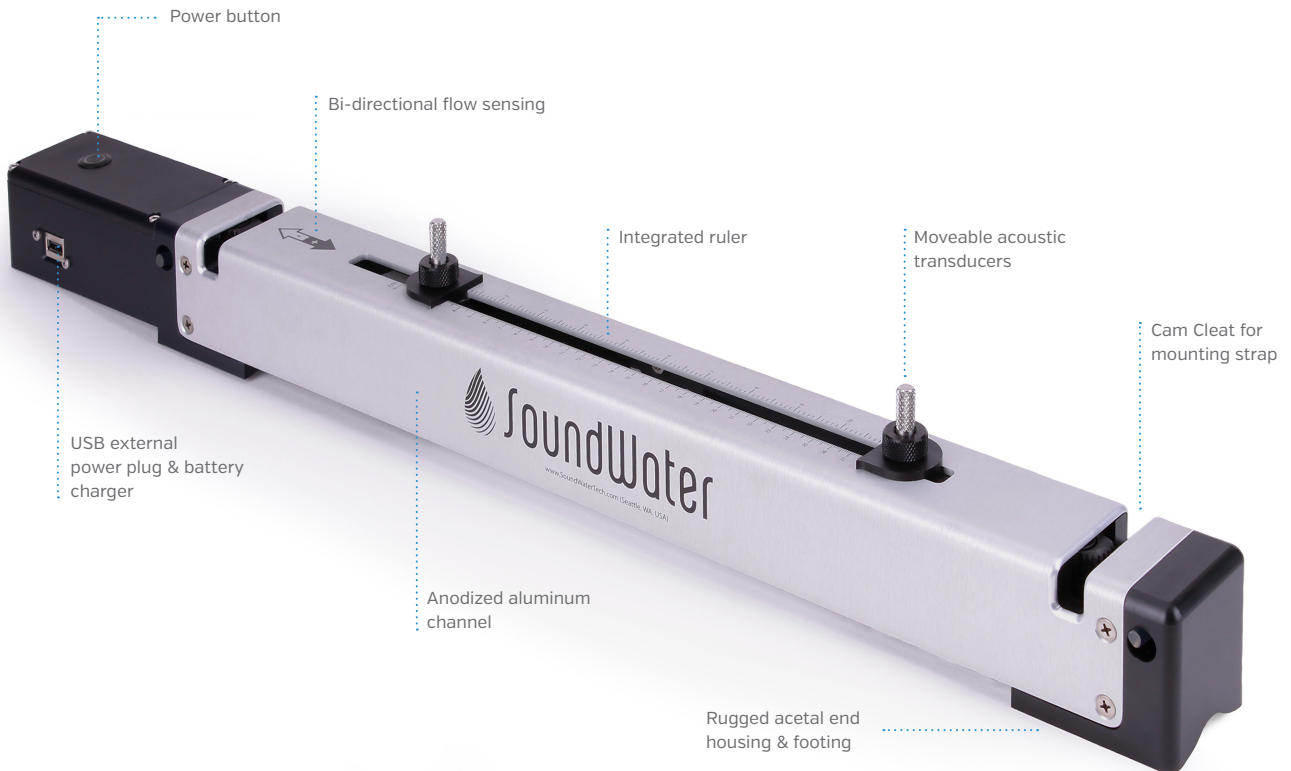

Orcas Specifications*

Installation	Installs on pipe from 1" to 20" nominal diameter depending on hardware selection 15 pipe diameters upstream; 5 diameters downstream required for optimal performance [typical] Maximum diameter depends upon pipe material [20" for plastic, 18" for metal]			
Pipe Materials	Metal: Steel, Stainless Steel, Copper, Brass, Aluminum Plastic: PVC, HDPE, PIP			
Flow Range	Bi-directional; 0.1 ft/s to 20 ft/s [0.03 m/s to 6 m/s]			
Performance	±1.0% to 2.0% accuracy typical [for pipe sizes >1.5"] ±2.0% to 3.0% accuracy typical [for pipe sizes <1.5"] 0.5% repeatability *Under standard conditions, assuming fully developed and symmetrical flow profile [typically taken on a straight run of 15 diameters upstream and 5 diameters downstream; flow rate above 3 ft/s or 1m/s; non-aerated liquids]. If the equipment is used in a manner not specified by the manufacturer, the protection provided by the equipment may be impaired.			
Display	Flow measurements display on SoundWater Technology's Orcas™ App [iOS or Android] Mobile devices connect wirelessly to Orcas™ with Bluetooth 4.0 [BT LE] Metric and English units			
Data Logger	Store up to 14 days of flow data			
Software	Save and recall site setup information Mobile device App for iPhone, iPad, iPod touch and Android devices [*For Android devices, Samsung recommended]			
Hardware	PIPE SIZE RANGE	LENGTH	PIPE MATERIALS	
	Orcas Mini	1" to 4.5"	19"	Steel, Stainless, Copper, Brass, Aluminum, Plastics
	Orcas Short	2" to 12"	22"	Steel, Stainless, Aluminum, Plastics
	Orcas Standard	2" to 12"	29"	Steel, Stainless, Copper, Brass, Aluminum, Plastics
	Orcas Extended	2" to 20"	29"	Steel, Stainless, Aluminum, Plastics
Power	Rechargeable battery [12+ hours], or USB-powered continuous operation [5 volts]** 0.5W Max [100 mAmp max current; when discharging]; 9W Max [1.5 Amp max current, when charging] 5 "AA" NiMH 6V pack with thermistor **Use only the charger provided with the Flowmeter. Battery holds charge for 5 months when not in use. **Charger compatible with 110/220VAC 50/60 Hz.			
Power Adapter	For recharging battery - must use the 12W USB power adapter supplied with the Orcas			
Environmental	Ambient and flow temperatures -20° to 150° F [-20° to 65° C] Optional high temperature option -20° to 212° F [-20° to 100° C] IP65 splash proof Weather resistant			
Materials	Body: Anodized aluminum channel, acetal end housings and feet Mounting Straps: EPDM			
Manufacture	SoundWater Technologies, United States			

*Specifications subject to change.

Technology

The transit time flowmeter operates by alternately transmitting and receiving a burst of sound energy between the two transducers.

The burst is first transmitted in the direction of fluid flow and then against fluid flow.

Since sound energy in a moving liquid is carried faster when it travels in the direction of fluid flow [downstream] than it does when it travels against fluid flow [upstream], a difference in the travel times will occur. The sound's travel time is accurately measured in both directions and then used to compute the flow rate.

Sound waves can bounce in many directions as they travel through various materials. The more the sound waves scatter, the fewer actually reach the second transducer. The Orcas uses sophisticated methods to maximize transducer efficiency, thus allowing the unit to run on very low power. Focusing of the sound wave is also important to ensure it reaches the second transducer without degrading. This is accomplished by accurately spacing the transducers to allow for optimum sound transit between transducers. The Orcas app computes this spacing based on the pipe size, pipe material, and type of liquid.

Transit time technology works best in clean or mildly dirty water or fluids with minimal turbulence or flow distortion.

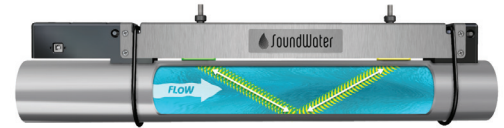

Dimensions

Orcas Mini



Orcas Short



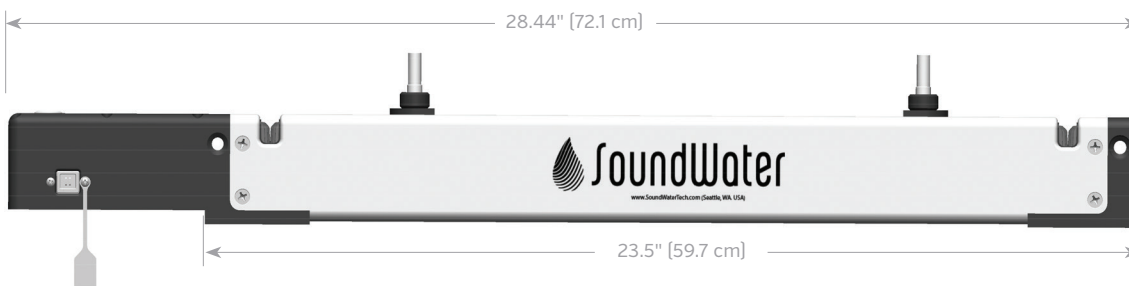

Orcas Standard and Orcas Extended





App Features

Interactive smart phone/tablet control app—iOS or Android.

-  Save location information
-  Handy built-in pipe specifications
–or add your own
-  Drag and drop output selection



-  English or metric units
-  Easy-to-use data logging
-  Select liner and liquid types
–or define your own



App Installation

Getting Started

Begin by downloading the Orcas App to your iPhone™, Android phone, or other Bluetooth enabled mobile device from the Apple Store™ or Google Play™. [Note: On an iPad, you must select iPhone Only in the app store.] If you do not have automatic updates enabled on your device, be sure to update your app when notified that there is a new version available.



Standard Version
(works for Mini,
Standard & Extended)

NOTE:

If you do not find the app, be sure your mobile device supports Bluetooth 4.0 [BT LE].

The following iOS devices support Bluetooth 4.0: iPhone 4S and later, iPad 3rd generation and later, iPad mini, iPad Air, and iPod Touch 5th generation.

If you have an Android device, check the settings on the device or specifications for the device.

Location Setup

Launching the app lands you on the locations screen. The app always begins with this screen at launch, making it easy to access previously saved location settings.

Begin by tapping on the add location (+) button.

Give your location a name and then set the specific parameters for that location. Each location's settings are stored in the Orcas App, ready for reuse.

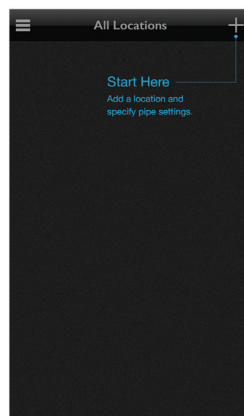

+
Add location

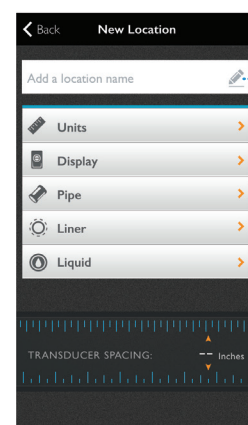

Name your location

Parameter Setup

Use the handy parameter selection screens to set your units of measure and display preferences. Conveniently select pipe, liner, and liquid specifications from lists of pre-loaded values. Don't see the right option? Add your custom values.

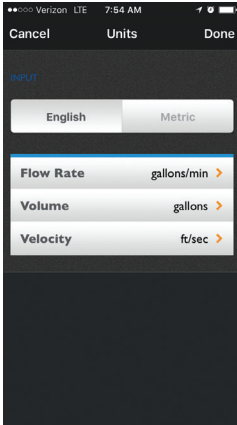

Units

Toggle between **English** and **metric** units of measure.

Select **Flow Rate**, **Volume**, and **Velocity** from our pre-loaded values.

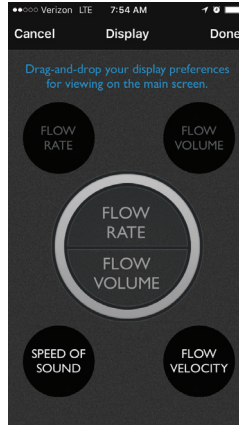

Display

The main screen displays two outputs. Drag and drop the two outputs that you rely on most to display on the main screen.

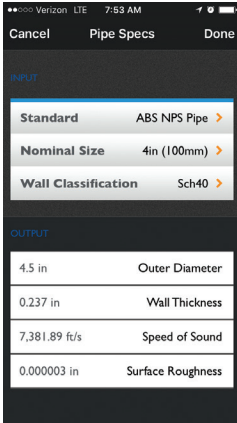

Pipe

Select **Pipe Type**, **Size**, and **Wall Classifications** from our pre-loaded values or add custom values by selecting Custom under Pipe Type. When entering a custom type, you must supply the outer diameter, wall thickness, speed of sound through the pipe material, and the surface roughness—enter zero if unknown roughness.

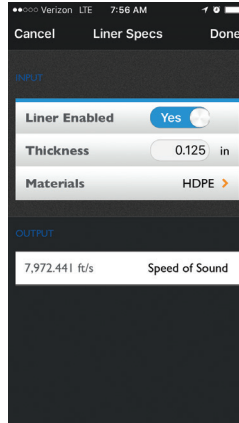

Liner

Switch between liner and no liner. When selecting **Liner Enabled**, enter **Liner Thickness** and choose **Liner Material** from our pre-loaded list or add custom values. When adding a custom material, you must enter the speed of sound through that material.

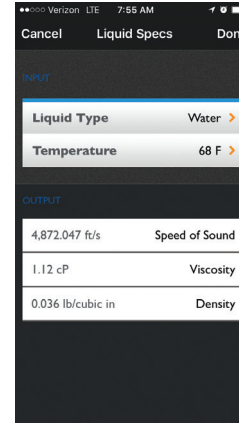

Liquid

Select **Liquid Type** and **Temperature** from our pre-loaded list of values or add a custom liquid type. When adding a custom liquid, you will need to enter the speed of sound through that liquid, the viscosity, and the density.

Flowmeter Installation

Straight Pipe Recommendations [X = diameter]

Reduced Pipe

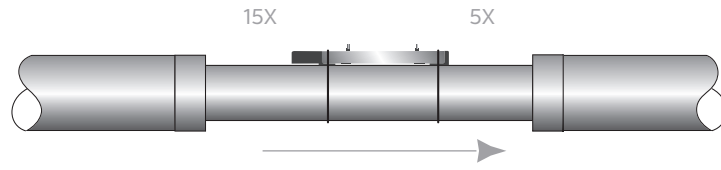

Two Elbows In Plane

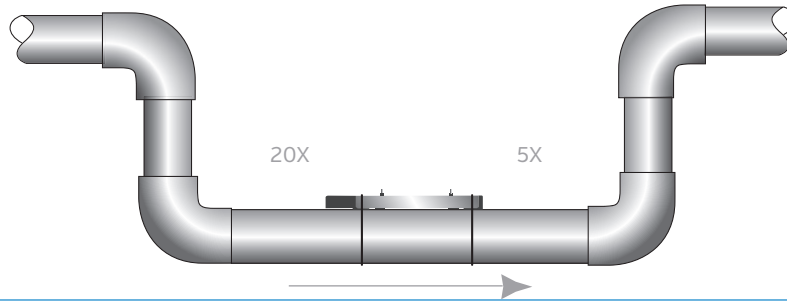

Two Elbows, Out Of Plane

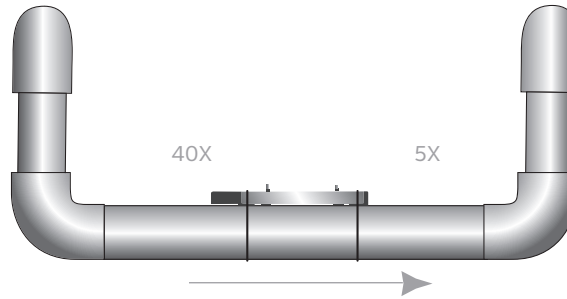

Expanded Pipe

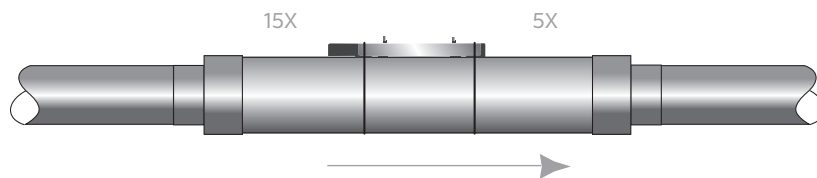

Swirling Flow: Propeller Meter

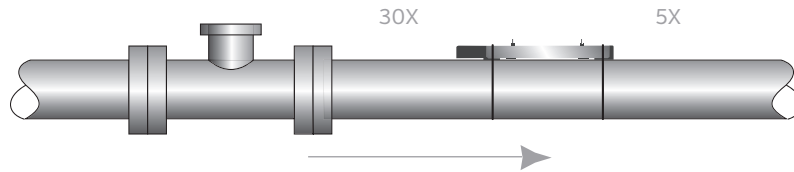

Swirling Flow: Partially Open Butterfly Valve

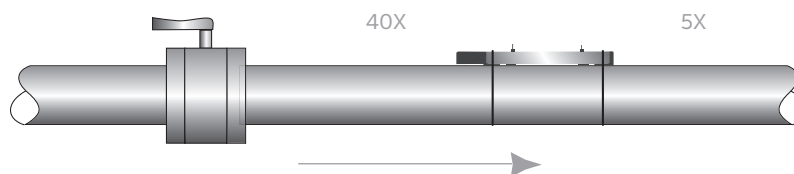

Full Pipe Recommendations

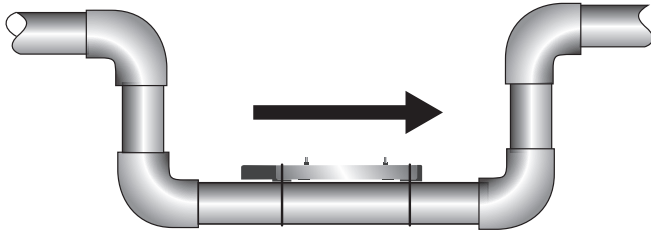

Recommended:

Keep pipe full at meter for accuracy

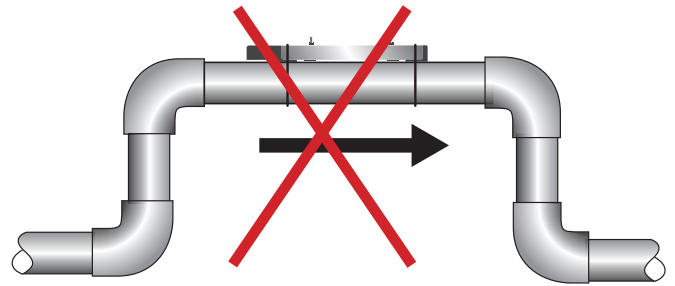

Not Ideal:

Allows air pockets to form at meter

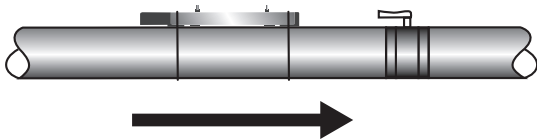

Recommended:

Keeps pipe full at meter for accuracy

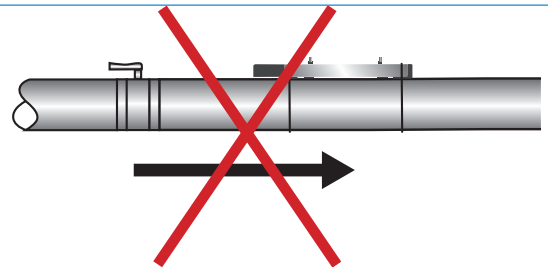

Not Ideal:

Post-valve cavitation can create air pocket

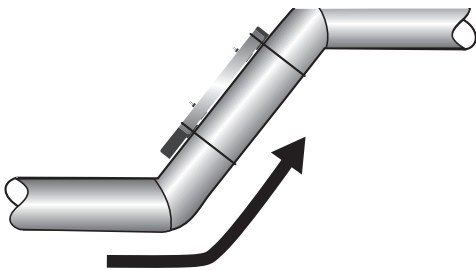

Recommended:

Allows air to bleed off

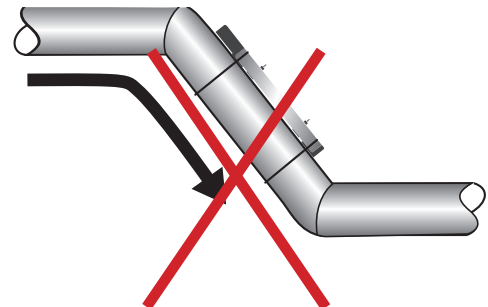

Not Ideal:

Air can be trapped

Flowmeter Orientation

This is a view looking directly into a pipe, with the meter in multiple possible positions on the side of the pipe. Horizontal [3 o'clock or 9 o'clock position] is the preferred installation orientation, since it avoids problems with trapped air and sediment.

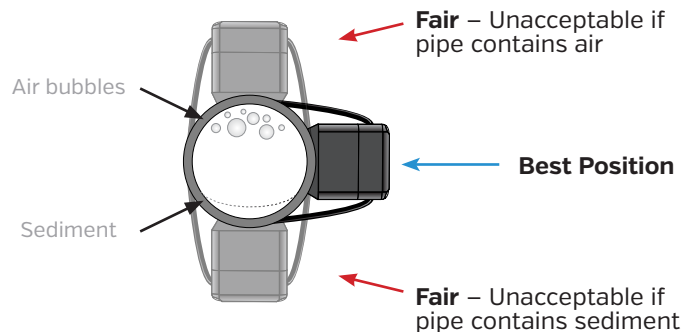

Transducer Spacing

Once you entered your parameters in the previous section, the app automatically computed the proper transducer spacing. This is shown at the bottom of the main app screen.

The next step is to adjust the transducer spacing on the flowmeter, as follows:

1. Rotate the black knob to unlock the horizontal motion for each transducer.
2. Move the transducers to the specified transducer spacing by sliding them along the integrated ruler. Note: It is not necessary to start at zero on the ruler, so long as the actual spacing is correct.
3. Lock into place using the black knobs. This is important to prevent the transducer spacing from moving when mounting the flowmeter!

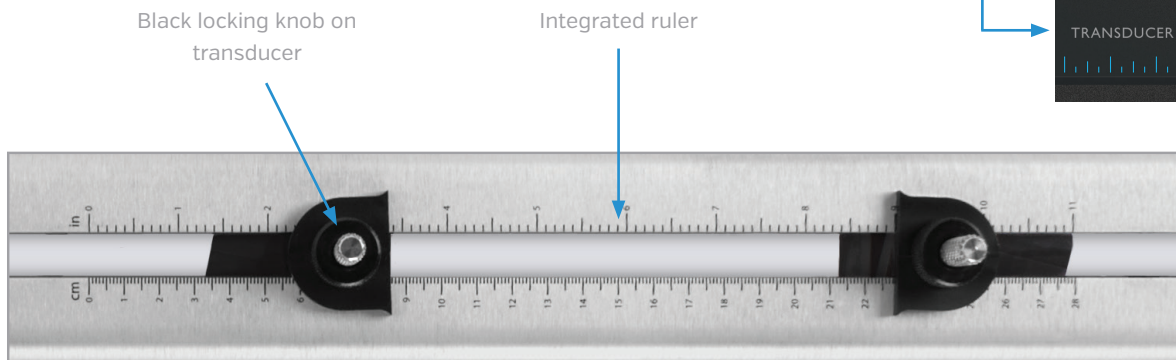
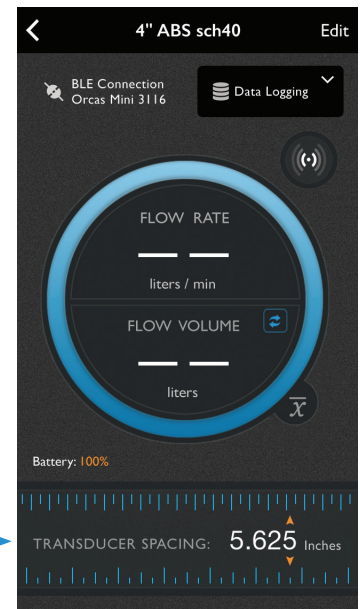

Power Considerations

Your Orcas Flowmeter battery has been fully charged at the factory before shipping and is ready to go.* When it's time to recharge the battery, the app will let you know.

When using the data logging function and **recording for more than 12 hours, the Orcas must be connected to a power source**, such as a portable USB power bank or a USB power adapter connected to an external power source.

* On a full charge, the Orcas will have a shelf life of up to five months. It is a good idea to charge the unit for a full five hours if it hasn't been used for a month or two. On a full charge the meter should operate for up to 12 hours of continuous use. Note that if the battery is flat, the power button LED will blink rapidly for five seconds and then the meter will turn off.



When recording more than 12 hours, the Orcas must be connected to an external power source, such as the USB power adapter supplied with the Orcas.

Installing the Flowmeter

Once the transducer spacing has been set and locked in place, you are ready to install the flowmeter on your pipe.

1. Rotate the silver knobs counter clockwise until they stop. This raises the transducers up above the meter footings.
2. Apply coupling gel liberally to the transducer faces, covering the entire bottom face of each transducer.
3. Place flowmeter on pipe, assuring that the footings are flush with the pipe and the meter is aligned with the axis of the pipe.
4. Strap the meter to pipe with the mounting straps, clamping the straps into the cam cleats. Hand tighten only!
5. Rotate silver knobs clockwise to press transducers onto the pipe. Hand tighten only until seated firmly.

Warning: Tightening too much can lift the meter away from the pipe, causing incorrect readings.

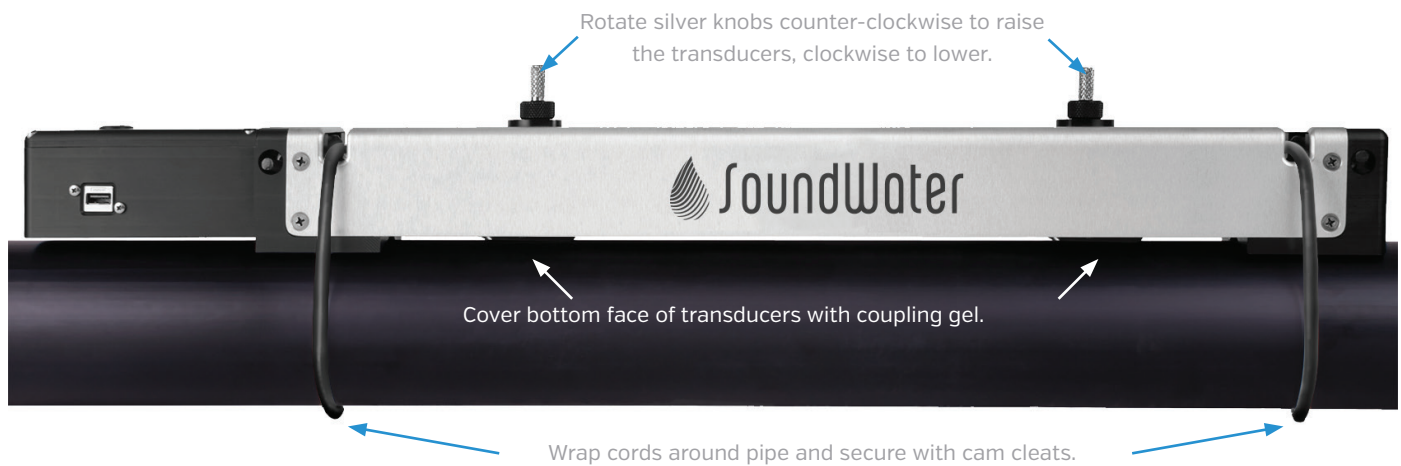

Do's and Don'ts

- Do** charge your Orcas at least once a month.
- Do** store your Orcas in a dry, inside area when not in use.
- Do** store your Orcas fully charged.
- Do** keep your Orcas in its protective case when transporting to prevent damage.
- Do** gently clean the transducer pads regularly with isopropyl alcohol to prevent hardening and build up of used coupling gel.
- Don't** charge with any charger other than the 12W charger supplied. Other chargers may damage the Orcas.
- Don't** store, transport, or use your Orcas where the device may exceed 150°F [65°C]—battery may leak or explode!
- Don't** bang or drop the Orcas on hard objects or surfaces.
- Don't** nick the transducer pads.

Operation

Collecting Your Data

Be sure the app is running on your mobile device.

Turn on power to the flowmeter by pressing the power button on the left top of the meter.

A steady LED indicates that power is on. The LED will flash if the meter is charging on external power. [Note: Older units may not flash.]

The app will display a list of all Orcas meters within its range. Tap the one you are currently using.

[Note: Your app will check the flowmeter to be sure it has the most recent programming. If there is a newer version available, it will give you the option of updating the meter. Updating the meter may take three to five minutes.]

Your flow data will display on the Orcas App.

When you are done collecting data, snap the cords out of their cam cleats and you are ready to move on to your next location. The next time you return to this location, the Orcas App will remember your settings.

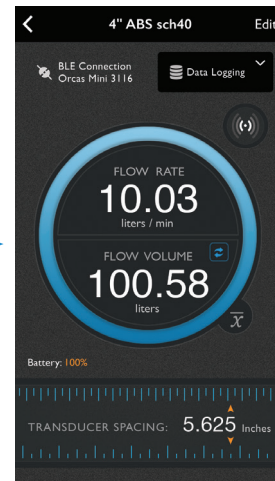
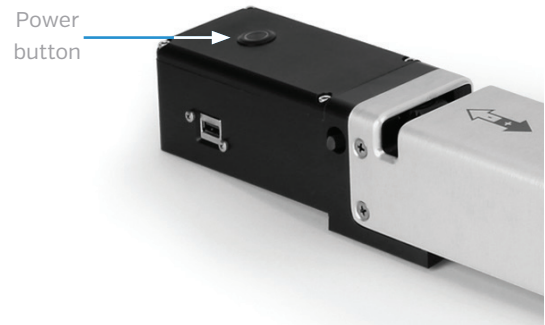

Data Logging



The purpose of the Orcas's built-in data logger is to record flow for a specified period of time. It may be used to conveniently record flow for as long as 14 days or as little as one minute. While conveniently battery powered, the Orcas has limited memory. Thus, only one data log may be used at any one time. As the Orcas data logger uses Bluetooth [BLE] to transfer data from the flowmeter to the mobile device, data transfer speed is limited by BLE, which is not designed to transfer large data sets. Transferring the maximum sized data set will take up to 5 1/2 minutes.

All data logging functions are accessed by tapping the Data Logging button in the measurement view.



The Orcas's data logger stores only one data set at any time, selecting "Rec" [which creates a new data log] will write over the existing data log. A message appears when selecting the "Rec" button indicating that the existing data log will be over-written if a new data log is started and gives the user the ability to continue with the new data log or to cancel.

Making a Recording

- Connect to the meter with the Orcas App.
- Tap the Data Logging button to access the data logger features.
- Using the slider bar in the app's data logger setup view, set the recording time. [See Explanation of Recording Times on the next page.]
- Tap “Rec” to start the recording. Data will start recording on the meter. You can disconnect the mobile app during recording. The meter will turn off when done to save power, unless still connected to the app.
- To stop recording prior to completing the time period, connect the Orcas App to the meter, tap the Data Logging button, and tap “Stop.”

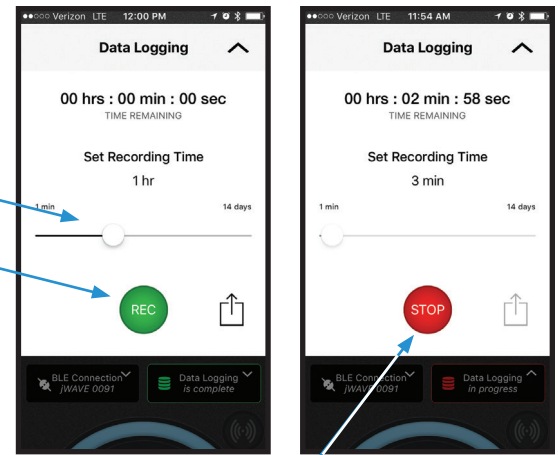

The status of the data logger is indicated by the color and text of the data logger setup button, located in the measurement view. If data logger is active, the button is outlined in red, shows a red disk drive, and displays the text “in progress.” If the data logger is completed, the button is outlined in green, shows a green disk drive, and displays the text “complete.” The data logger setup view also displays the remaining recording time for conveniently checking progress of data logging.



Active data logging session running.

Data logging session complete.



Upload data by tapping the “share” button.

Uploading Data

Data is stored on the flowmeter and may be retrieved at any time. To upload data, the data logger must be either complete or stopped and the app must be connected to the flowmeter. Data is uploaded using the “share” button located to the right of the “Rec” button. Uploading the maximum sized data set may take up to 5 1/2 minutes.

If you want to quickly review your data at any time, tap the “share” button, and then tap Quick Look. This displays the data log in a spreadsheet for immediate viewing on your mobile device.

Sharing Data

You only need to upload the data log once from Orcas. Once the data is uploaded, it may be shared any number of times without additional uploading, until a new data log is started. Tap the “share” button to share the data by a number of methods, email, text, AirDrop, etc. Shared data is formatted in a CSV file (comma delimited file). The file name is unique and contains both the date and time that the data log was started as well as the location name. Setup information such as the date and time the data log was started, the number of samples, sampling period, and location name are located at the top of the data file. The data is arranged in rows, where each row contains a single flow measurement including sample number, time stamp, flow rate, velocity, volume, and quality. The data file can be viewed or printed as a text file or formatted using most spreadsheet and database programs, such as Microsoft® Excel or Access.

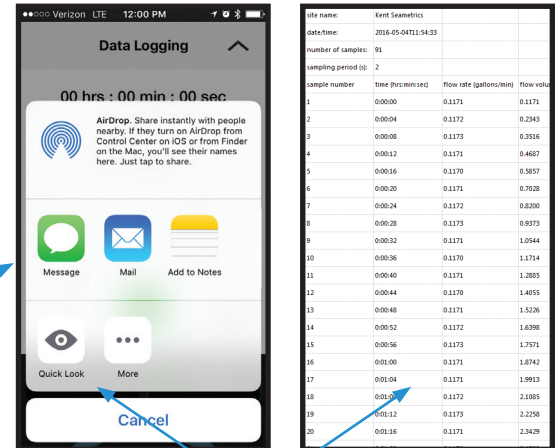

Tap “Quick Look” for immediate viewing of your data.



NOTE: The app must be connected to the Orcas in order to share the data or view it with Quick Look.

Explanation of Recording Times

The sampling rate (time between each recorded flow measurement) and total number of recorded measurements is controlled by the Orcas. The maximum possible number of flow measurements is 3750 and each includes five values--flow rate, total, velocity, time stamp, and quality. The maximum sampling rate is two seconds.

The Orcas data logger will attempt to maximize the sampling rate, based on the your selected recording time. For example, if you select to record flow for one minute, then the Orcas maximizes the sampling rate at two seconds and will record 31 flow measurements (covering a total of 60 seconds).

If you select to record flow for four days, then the Orcas again attempts to maximize the number of flow measurements; however since there is not enough memory to record flow every two seconds for four days, it configures the sampling period to maximize the number of flow measurements. For the case of four days, the Orcas sets the sampling period at 92 seconds giving you over 3500 flow measurements.

Length	Sample Period
1 minute	2 seconds
1 hour	2 seconds
10 hours	9 seconds
1 day	23 seconds
4 days	92 seconds (1 min. 32 sec.)
10 days	230 seconds (3 min. 50 sec.)
14 days	322 seconds (5 min. 22 sec.)



When recording more than 12 hours, the Orcas must be connected to an external power source, such as the USB power adapter supplied with the Orcas.

Troubleshooting

Problem	Probable Causes	Things to try...
Battery not charging	Using wrong power supply	Use the supplied 12W charger/power supply
No signal	<p>Incorrect setup</p> <p>Air in pipe</p> <p>Corroded rusty pipe</p>	<p>Confirm pipe settings</p> <p>Rotate meter to 3 o'clock position</p> <p>Remove air</p> <p>Relocate meter to another location where there is no air</p> <p>Relocate meter to clean section of pipe. If no clean section is available, move meter to other locations until a signal is found—try to find a section of pipe with less corrosion or rust.</p>
Orcas App not displaying any flowmeters to connect	<p>Bluetooth not enabled</p> <p>Mobile device not Bluetooth 4.0+, LE (Low Energy).</p>	<p>Open your iOS or Android system settings App and enable Bluetooth. Close, and relaunch the Orcas App.</p> <p>Orcas App is compatible only with Bluetooth 4.0 (or later), also known as Bluetooth LE, or Bluetooth Low Energy. Most mobile devices are BLE enabled; however some older devices may use standard Bluetooth and may not be compatible.</p>



1-509-899-7838



sales@soundwatertech.com



support@soundwatertech.com



soundwatertech.com