



SoundWater Orcas SP™ Fluid flow sensing, redefined

Transit Time Ultrasonic Flowmeter

Instruction Guide
For Orcas SP Mini, Orcas SP Standard
and Orcas SP Extended

Contents

General Information

Page

General Information	3
Meter Features	3
Specifications	4
Dimensions	4
App Features	5
Technology	5
Do's and Don'ts	5

App Installation

Getting Started	6
Location Setup	6
Parameter Setup	7

Flowmeter Installation

Straight Pipe Recommendations	8
Full Pipe Recommendations	9
Flowmeter Orientation	9
Transducer Spacing	10
Wiring Power and Outputs	10
Installing the Flowmeter	12

Operation

Collecting Your Data	13
Data Logging	13

Troubleshooting

Problems	16
Probable Causes	16
Things to Try	16

This device complies with Part 15 of FCC Rules and Industry Canada license-exempt RSS standard(s). Operation is subject to the following two conditions: [1] this device may not cause harmful interference, and [2] this device must accept any interference received, including interference that may cause undesired operation. Contains FCC ID: XDULE40-S2, Contains IC: 8456A-LE4S2. CAN ICES-1/NMB-1; CAN ICES-3 [B]/NMB-3[B]

MODEL: SWT ORCAS-01

General Information

Meet Orcas SP (Semi Permanent). Now you can capture accurate and reliable flow readings with any SCADA, PLC system, or the Ayyeka Wavelet with less hassle and in less time—wherever you need a flow or volume measurement.

No wires. No bulky electronics box to lug around. Your ultrasonic sensor hardware installs on the outside of your pipe in a snap—and senses through the pipe wall. Your mobile device helps you set up the hardware and displays readings. So you'll get your job done more quickly, every time.

The semi permanent nature combines the fast, easy install of a portable flowmeter plus external power and communications common to permanent installations. Orcas SP has the best of both worlds—making your job fast, easy, and hassle free.

The solution starts with the Orcas App (downloadable from the app stores) and works on both iOS and Android devices. The companion Orcas SP Sensor is a compact, clamp-on ultrasonic transducer device that transmits flow measurements to any SCADA, PLC, or Ayyeka Wavelet (for cellular data collection and web interface).

Connect easily to your custom process. Orcas SP comes fitted with a robust, 5-pin M12 circular connector for wiring to your PLC, SCADA, flow controller or custom process hardware. Orcas gets external power for continuous use, and delivers 4-20 mA, pulse, or MODBUS RTU - so your systems can record flow.

For remote applications (or where hard-wired communication is impractical, make Orcas SP an IoT device by adding the Ayyeka Wavelet. Wavelet seamlessly transmits flow data from your Orcas SP using mobile networks—and you access your data through any web browser. Now you can quickly locate any of your flow installations around the world, and analyze live flow measurements and a graphical flow history from virtually anywhere.

The durable mechanical design is o-ring sealed and gasketed for long term, and reliable use in outdoor environments.

Bi-directional readings are transmitted to your process hardware or wirelessly to any mobile device for display.

Meter Features

All Orcas SP models including the Mini, Standard and Extended include the same features shown below.

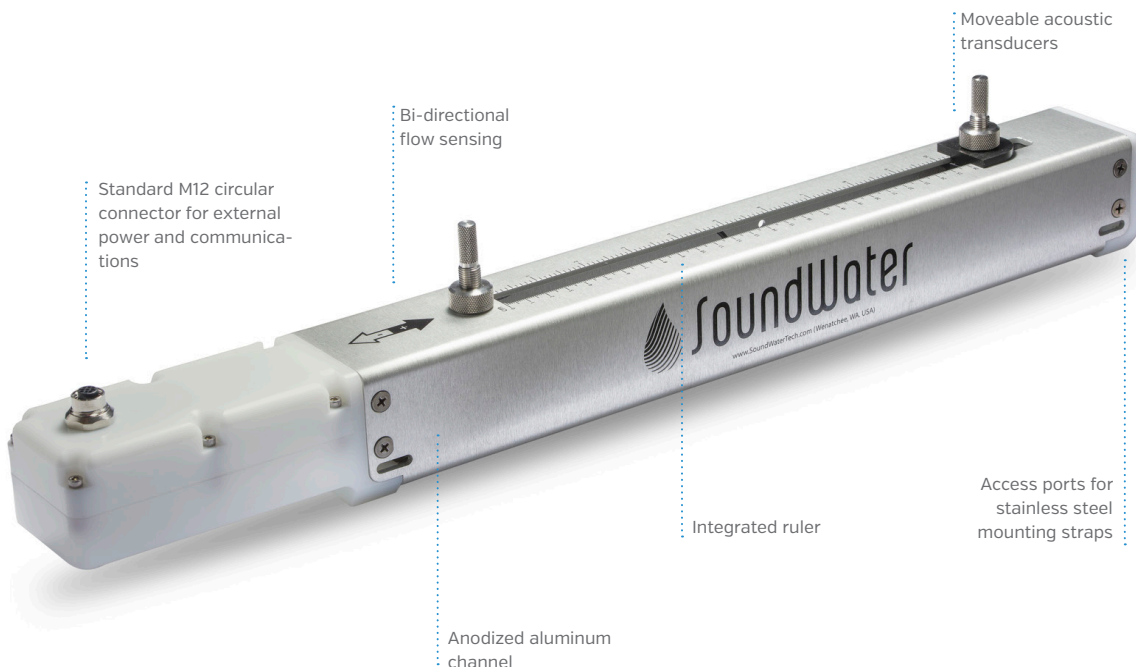

Orcas SP Specifications*

Pipe Materials	Metal: Steel, Stainless Steel, Copper, Brass, Aluminum Plastic: PVC, CPVC, HDPE, PE, PIP															
Installation	Installs on pipe from 1" to 26" nominal diameter depending on hardware selection 15 pipe diameters upstream; 5 diameters downstream required for optimal performance [typical]															
Flow Detection Range	Bi-directional; 0.1 ft/s to 20 ft/s (0.03 m/s to 6 m/s)															
Performance	<table><thead><tr><th>PIPE SIZE</th><th>ACCURACY</th><th>OPERATING RANGE</th><th>REPEATABILITY</th></tr></thead><tbody><tr><td>3" to 26"</td><td>±1.0% to 2.0% typical</td><td>-20 to 20 ft/s [-6 to 6 m/s]</td><td>0.5%</td></tr><tr><td>1" to 2"</td><td>±2.0% to 3.0% typical</td><td>-20 to 20 ft/s [-6 to 6 m/s]</td><td>0.5%</td></tr></tbody></table> <p>*Under standard conditions, assuming fully developed and symmetrical flow profile [typically taken on a straight run of 15 diameters upstream and 5 diameters downstream; flow rate above 3 ft/s or 1m/s; non-aerated liquids]. If the equipment is used in a manner not specified by the manufacturer, protection provided by the equipment may be impaired.</p>	PIPE SIZE	ACCURACY	OPERATING RANGE	REPEATABILITY	3" to 26"	±1.0% to 2.0% typical	-20 to 20 ft/s [-6 to 6 m/s]	0.5%	1" to 2"	±2.0% to 3.0% typical	-20 to 20 ft/s [-6 to 6 m/s]	0.5%			
PIPE SIZE	ACCURACY	OPERATING RANGE	REPEATABILITY													
3" to 26"	±1.0% to 2.0% typical	-20 to 20 ft/s [-6 to 6 m/s]	0.5%													
1" to 2"	±2.0% to 3.0% typical	-20 to 20 ft/s [-6 to 6 m/s]	0.5%													
Outputs [optional]	CURRENT (4-20 MA) Current proportional to flow; user programmable. PULSE NFET (NPN type) open drain output with frequency proportional to flow; user programmable. MODBUS RTU RS485 , user programmable port settings.															
Display	Flow measurements display on SoundWater's Orcas™ App (Apple, Samsung, or Google devices preferred) Mobile devices connect wirelessly to Orcas™ with Bluetooth 4.0 [BT LE] Metric and English units															
Data Logger	Store up to 14 days of flow data															
Software	Save and recall site setup information Mobile device App for iPhone, iPad, iPod touch and Android devices															
Hardware	<table><thead><tr><th></th><th>PIPE SIZE RANGE</th><th>PIPE MATERIAL</th></tr></thead><tbody><tr><td>Orcas SP Mini</td><td>1" to 4.5"</td><td>Steel, Stainless, Copper, Brass, Aluminum, PVC, HDPE, PIP</td></tr><tr><td>Orcas SP Standard</td><td>2" to 12"</td><td>Steel, Stainless, Copper, Brass, Aluminum, PVC, HDPE, PIP</td></tr><tr><td>Orcas SP Extended</td><td>2" to 18"</td><td>Steel, Stainless, Aluminum, PVC, HDPE, PIP</td></tr><tr><td>Orcas SP Extended+</td><td>2" to 26"</td><td>Steel, Stainless, Aluminum, PVC, HDPE, PIP</td></tr></tbody></table>		PIPE SIZE RANGE	PIPE MATERIAL	Orcas SP Mini	1" to 4.5"	Steel, Stainless, Copper, Brass, Aluminum, PVC, HDPE, PIP	Orcas SP Standard	2" to 12"	Steel, Stainless, Copper, Brass, Aluminum, PVC, HDPE, PIP	Orcas SP Extended	2" to 18"	Steel, Stainless, Aluminum, PVC, HDPE, PIP	Orcas SP Extended+	2" to 26"	Steel, Stainless, Aluminum, PVC, HDPE, PIP
	PIPE SIZE RANGE	PIPE MATERIAL														
Orcas SP Mini	1" to 4.5"	Steel, Stainless, Copper, Brass, Aluminum, PVC, HDPE, PIP														
Orcas SP Standard	2" to 12"	Steel, Stainless, Copper, Brass, Aluminum, PVC, HDPE, PIP														
Orcas SP Extended	2" to 18"	Steel, Stainless, Aluminum, PVC, HDPE, PIP														
Orcas SP Extended+	2" to 26"	Steel, Stainless, Aluminum, PVC, HDPE, PIP														
Power	12-24 VDC external power for continuous use 0.6W Typical [100 mAmp max current]															
Turndown	200:1															
Environmental	Liquid/pipe temperature -40° to 160° F [-40° to 70° C] Optional high liquid/pipe temperature -40° to 212 F [-40° to 100° C] Ambient temperature -40° to 100 F [-40° to 37° C] IP65 splash proof & weather resistant															
Materials	Body: Anodized aluminum channel, HDPE end housings and feet Mounting Straps: Stainless Steel															
Manufacture	SoundWater Technologies, United States															

*Specifications subject to change.

Technology

The transit time flowmeter operates by alternately transmitting and receiving a burst of sound energy between the two transducers.

The burst is first transmitted in the direction of fluid flow and then against fluid flow.

Since sound energy in a moving liquid is carried faster when it travels in the direction of fluid flow [downstream] than it does when it travels against fluid flow [upstream], a difference in the travel times will occur. The sound's travel time is accurately measured in both directions and then used to compute the flow rate.

Sound waves can bounce in many directions as they travel through various materials. The more the sound waves scatter, the fewer actually reach the second transducer. The Orcas uses sophisticated methods to maximize transducer efficiency, thus allowing the unit to run on very low power. Focusing of the sound wave is also important to ensure it reaches the second transducer without degrading. This is accomplished by accurately spacing the transducers to allow for optimum sound transit between transducers. The Orcas app computes this spacing based on the pipe size, pipe material, and type of liquid.

Transit time technology works best in clean or mildly dirty water or fluids with minimal turbulence or flow distortion.

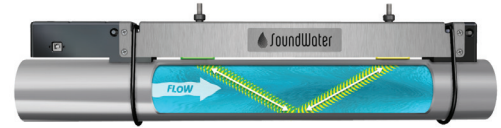

Dimensions

Orcas SP Mini



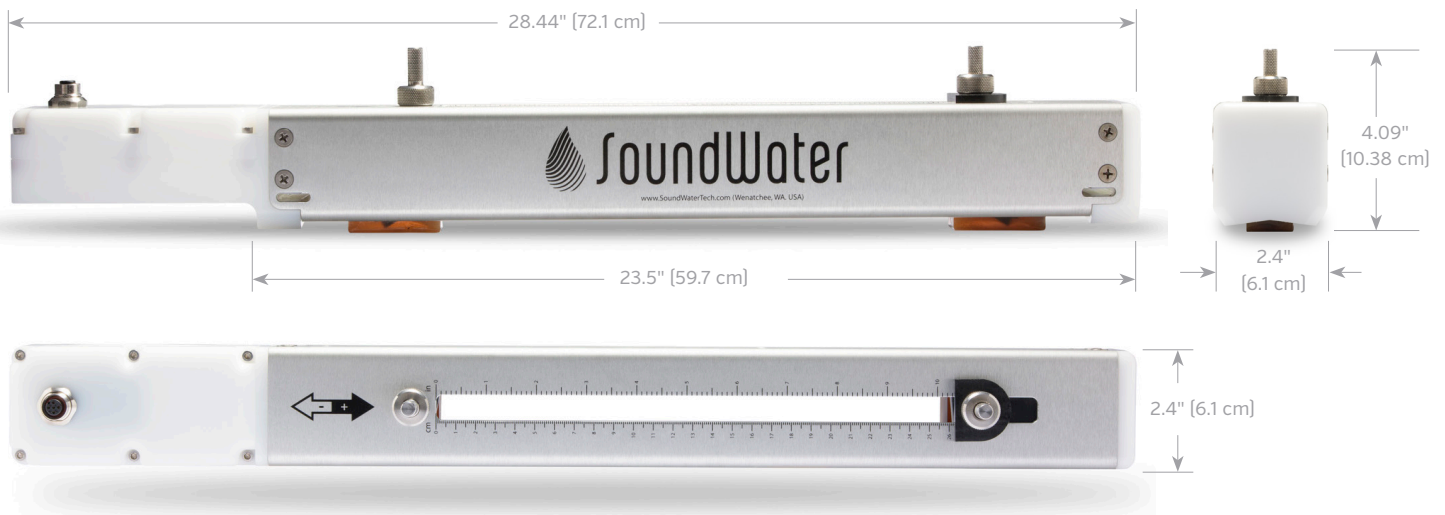

Orcas SP Standard and Orcas SP Extended





App Features

Interactive smart phone/tablet control app—iOS or Android.

-  Save location information
-  Handy built-in pipe specifications –or add your own
-  Drag and drop output selection



-  English or metric units
-  Easy-to-use data logging
-  Select liner and liquid types –or define your own



App Installation

Getting Started

Begin by downloading the Orcas App to your iPhone™, Android phone, or other Bluetooth enabled mobile device from the Apple Store™ or Google Play™. [Note: On an iPad, you must select iPhone Only in the app store.] If you do not have automatic updates enabled on your device, be sure to update your app when notified that there is a new version available.



Standard Version
(works for Mini,
Standard & Extended)

NOTE:

If you do not find the app, be sure your mobile device supports Bluetooth 4.0 [BT LE].

The following iOS devices support Bluetooth 4.0: iPhone 4S and later, iPad 3rd generation and later, iPad mini, iPad Air, and iPod Touch 5th generation.

If you have an Android device, check the settings on the device or specifications for the device.

Location Setup

Launching the app lands you on the locations screen. The app always begins with this screen at launch, making it easy to access previously saved location settings.

Begin by tapping on the add location (+) button.

Give your location a name and then set the specific parameters for that location. Each location's settings are stored in the Orcas App, ready for reuse.

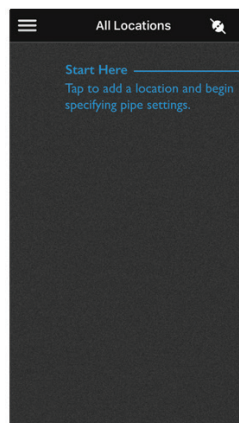

+
Add
location

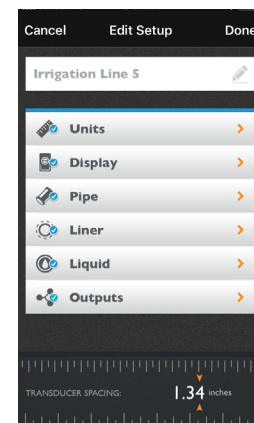

Name
your
location

Parameter Setup

Use the handy parameter selection screens to set your units of measure and display preferences. Conveniently select pipe, liner, and liquid specifications from lists of pre-loaded values. Don't see the right option? Add your custom values.

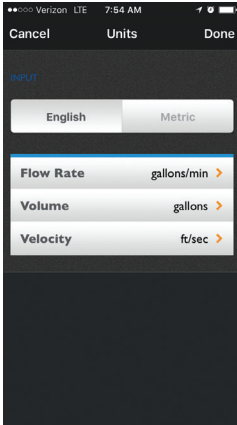

Units

Toggle between **English** and **metric** units of measure.

Select **Flow Rate**, **Volume**, and **Velocity** from our pre-loaded values.

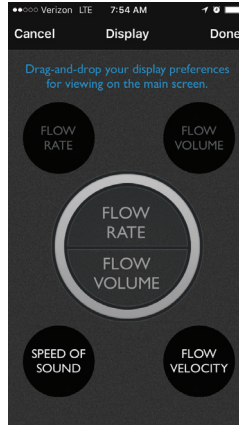

Display

The main screen displays two outputs. Drag and drop the two outputs that you rely on most to display on the main screen.

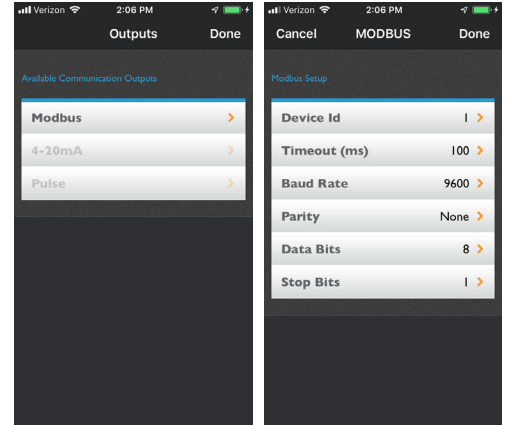

Hardware Outputs

Configure your hardware, MODBUS, 4-20mA & pulse outputs. 4mA is set to zero flow [for current output]. You only need to specify the flow rate at 20mA, or pulses per gallon [for pulse output].

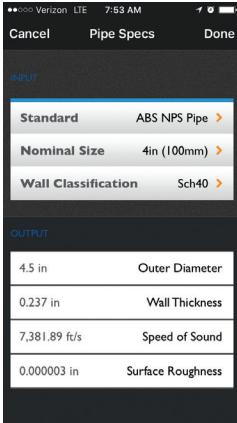

Pipe

Select **Pipe Type**, **Size**, and **Wall Classifications** from our pre-loaded values or add custom values by selecting Custom under Pipe Type. When entering a custom type, you must supply the outer diameter, wall thickness, speed of sound through the pipe material, and the surface roughness—enter zero if unknown roughness.

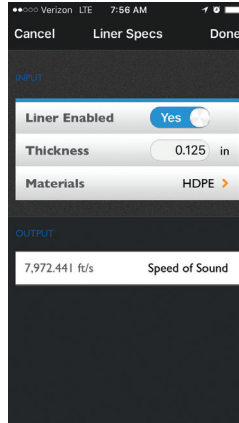

Liner

Switch between liner and no liner. When selecting **Liner Enabled**, enter **Liner Thickness** and choose **Liner Material** from our pre-loaded list or add custom values. When adding a custom material, you must enter the speed of sound through that material.

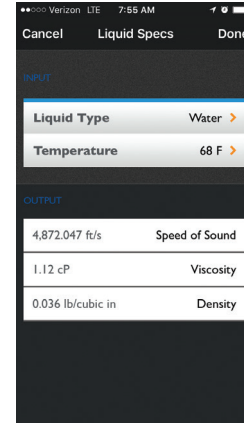

Liquid

Select **Liquid Type** and **Temperature** from our pre-loaded list of values or add a custom liquid type. When adding a custom liquid, you will need to enter the speed of sound through that liquid, the viscosity, and the density.

Flowmeter Installation

Straight Pipe Recommendations [X = diameter]

Reduced Pipe

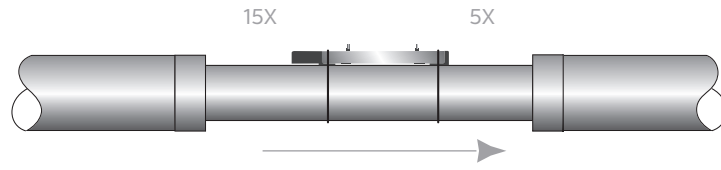

Two Elbows In Plane

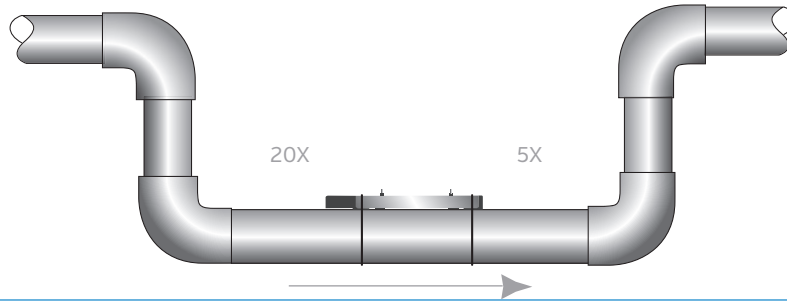

Two Elbows, Out Of Plane

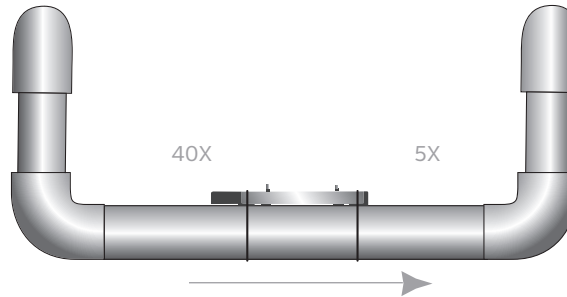

Expanded Pipe

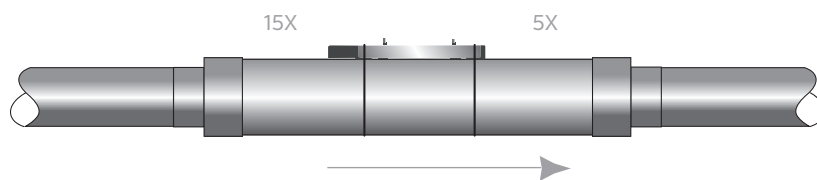

Swirling Flow: Propeller Meter

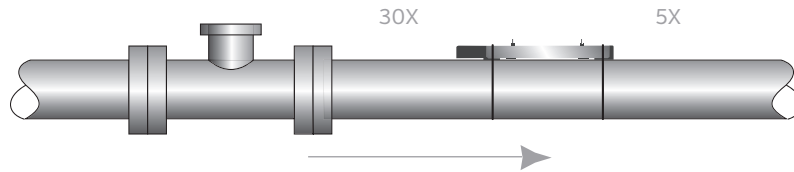

Swirling Flow: Partially Open Butterfly Valve

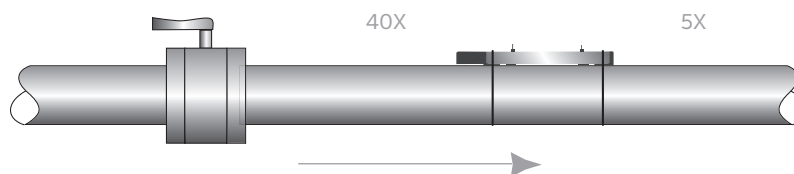

Full Pipe Recommendations

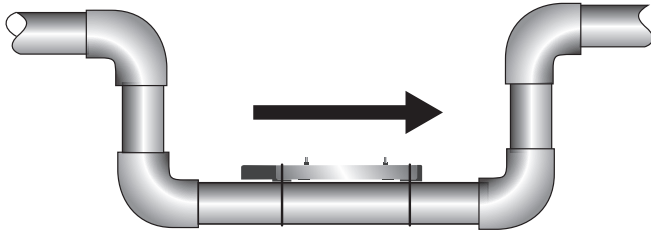

Recommended:

Keep pipe full at meter for accuracy

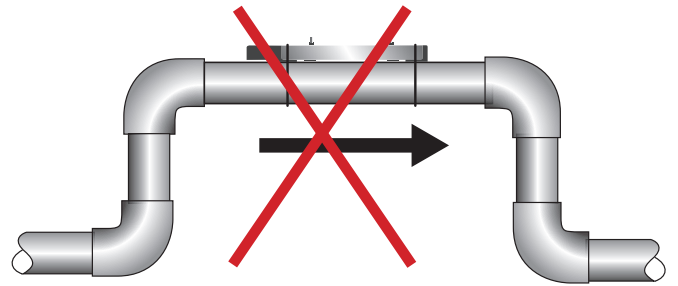

Not Ideal:

Allows air pockets to form at meter

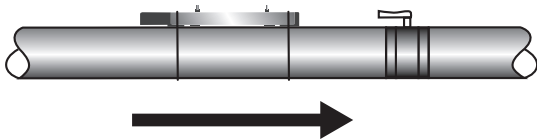

Recommended:

Keeps pipe full at meter for accuracy

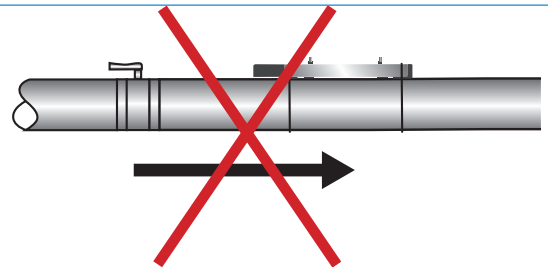

Not Ideal:

Post-valve cavitation can create air pocket

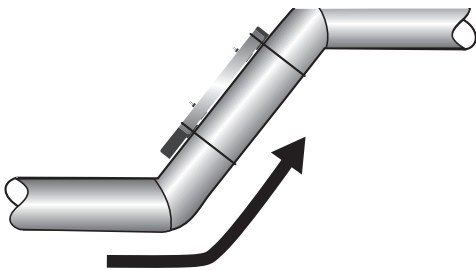

Recommended:

Allows air to bleed off

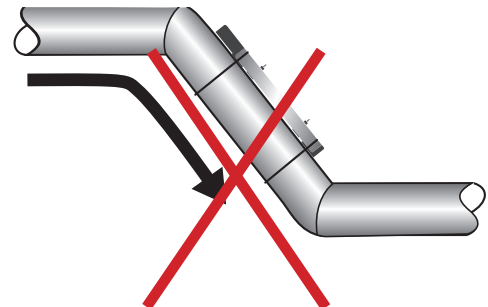

Not Ideal:

Air can be trapped

Flowmeter Orientation

This is a view looking directly into a pipe, with the meter in multiple possible positions on the side of the pipe. Horizontal [3 o'clock or 9 o'clock position] is the preferred installation orientation, since it avoids problems with trapped air and sediment.

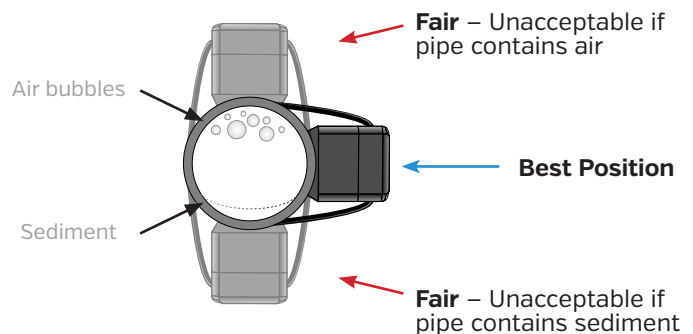

Transducer Spacing

Once you entered your parameters in the previous section, the app automatically computed the proper transducer spacing. This is shown at the bottom of the main app screen.

The next step is to adjust the transducer spacing on the flowmeter, as follows:

1. Rotate the large knob to unlock the horizontal motion for each transducer.
2. Move the transducers to the specified transducer spacing by sliding them along the integrated ruler. Note: It is not necessary to start at zero on the ruler, so long as the actual spacing is correct.
3. Lock into place using the large knob. This is important to prevent the transducer spacing from moving when mounting the flowmeter.

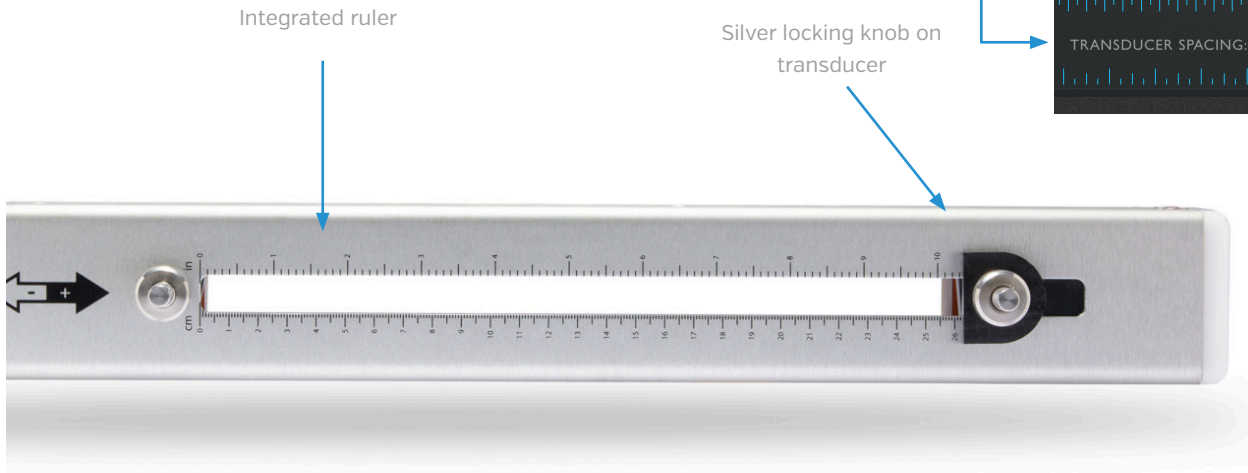
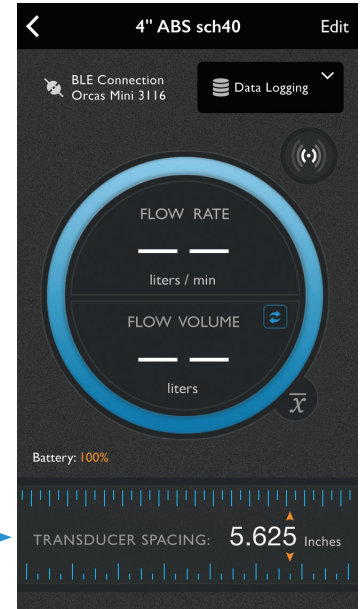

Connecting Power and Outputs

Connect 12-24V DC power using the supplied cable. Check the pinout diagrams at right for proper setup.

Flowmeter Pinout:

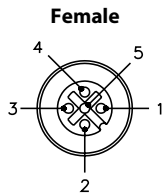

Supplied Cable Pinout:

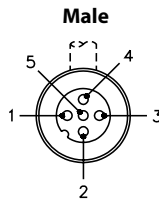

Supplied Cable Wire Colors and Pin Codes:

[for optional 4-20mA & Pulse]

- 1 Not Used
- 2 Pulse [NPN type open drain]
- 3 Power 12-24VDC [1.2W Max]
- 4 Power ground 0V
- 5 4-20mA active output

[for optional MODBUS RTU / RS-485]

- 1 Not Used
- 2 RS485 Data [A] -
- 3 Power 12-24VDC [1.2W Max]
- 4 Power ground 0V
- 5 RS485 Data [B] +

SoundWater recommends that you use the supplied connecting cable to wire your flowmeter. If you need a different length, use a compatible part to *Turk USA*, # *RSS 4.5T* [5 pin M12 Male Cordset].

Wiring

4-20mA Analog Output

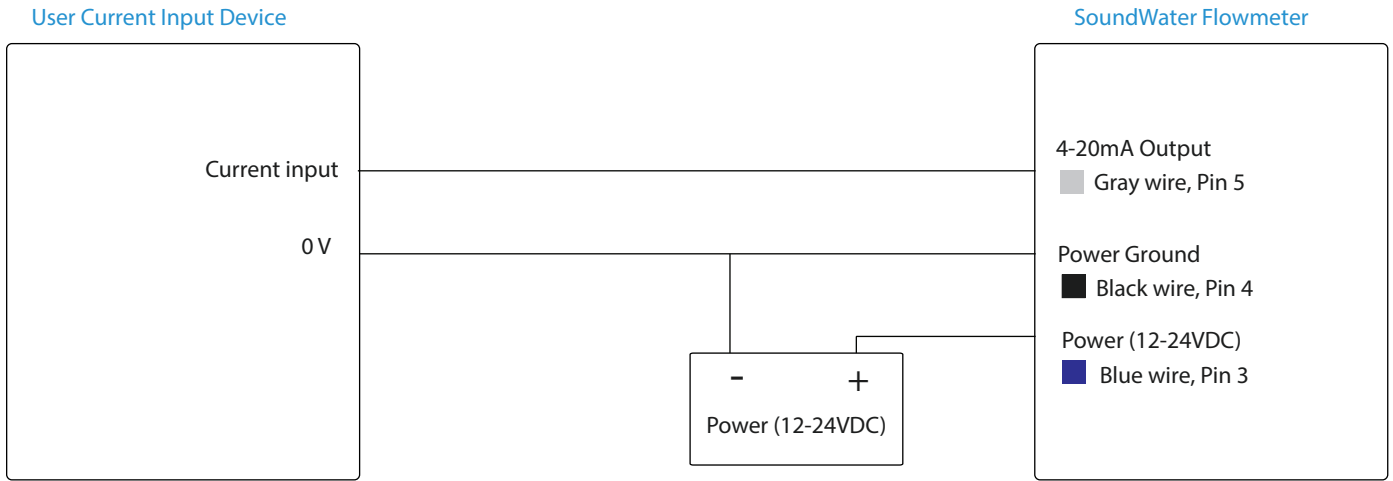

MODBUS RTU/RS-485 Output

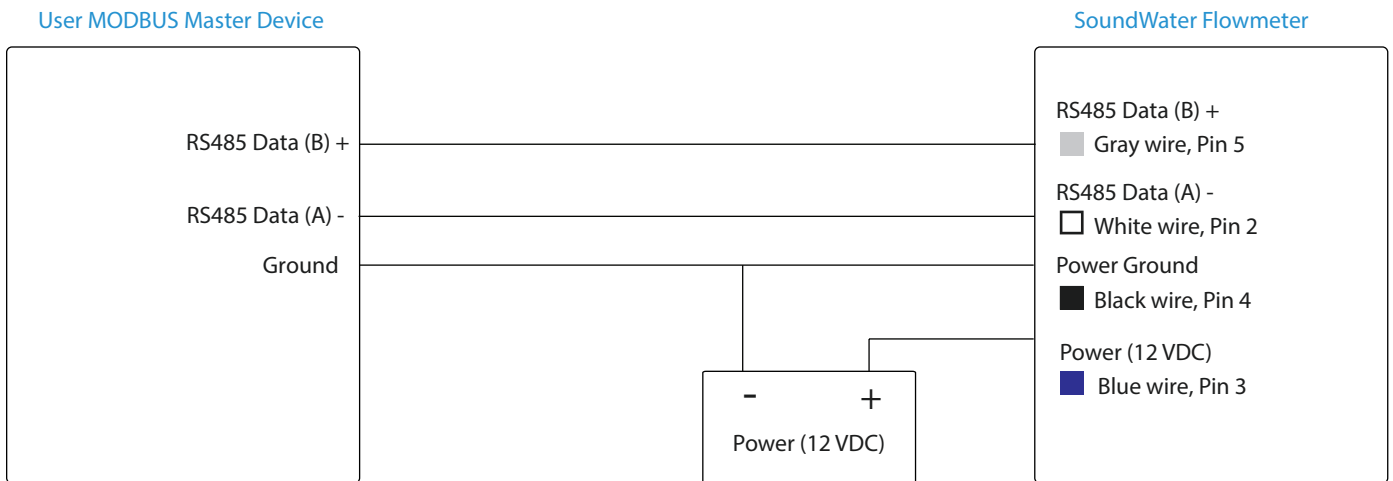

Pulse Output

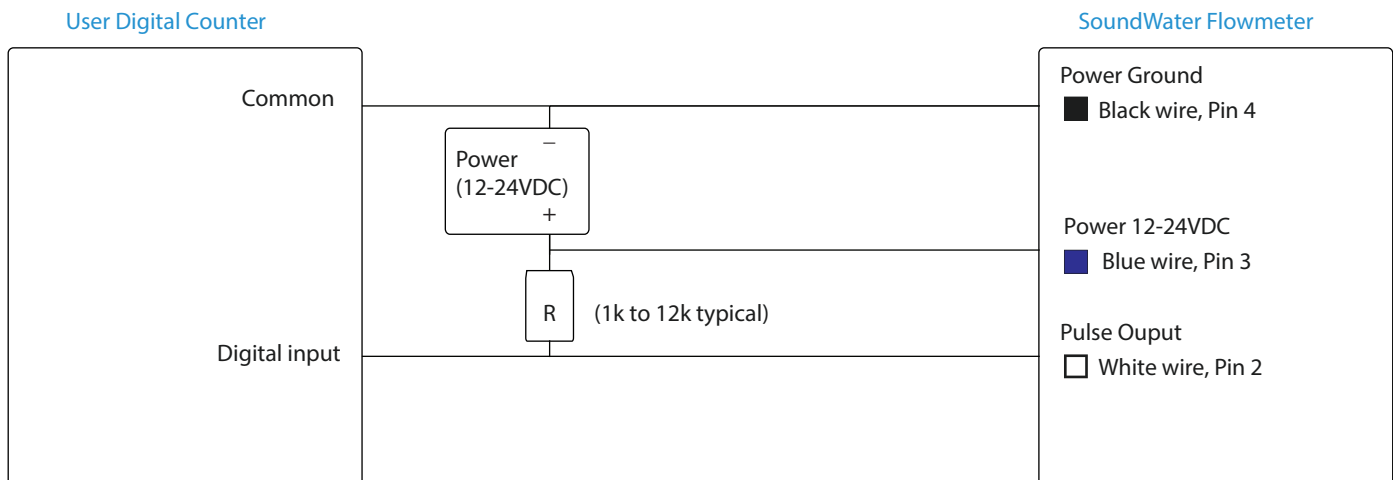

Installing the Flowmeter

Once the transducer spacing has been set and locked in place, you are ready to install the flowmeter on your pipe.

1. Thread the stainless steel mounting straps through the access ports located on either side of the flowmeter.
2. Rotate the thin silver knobs counter clockwise until they stop. This raises the transducers up above the meter footings.
3. Apply coupling gel liberally to the transducer faces, covering the entire bottom face of each transducer.
4. Place flowmeter on pipe, assuring that the footings are flush with the pipe and the meter is aligned with the axis of the pipe.
5. Strap the meter to pipe with the mounting straps, securing the straps with a socket or flat head driver.
6. Rotate thin silver knobs clockwise to press transducers onto the pipe. Hand tighten only until seated firmly.

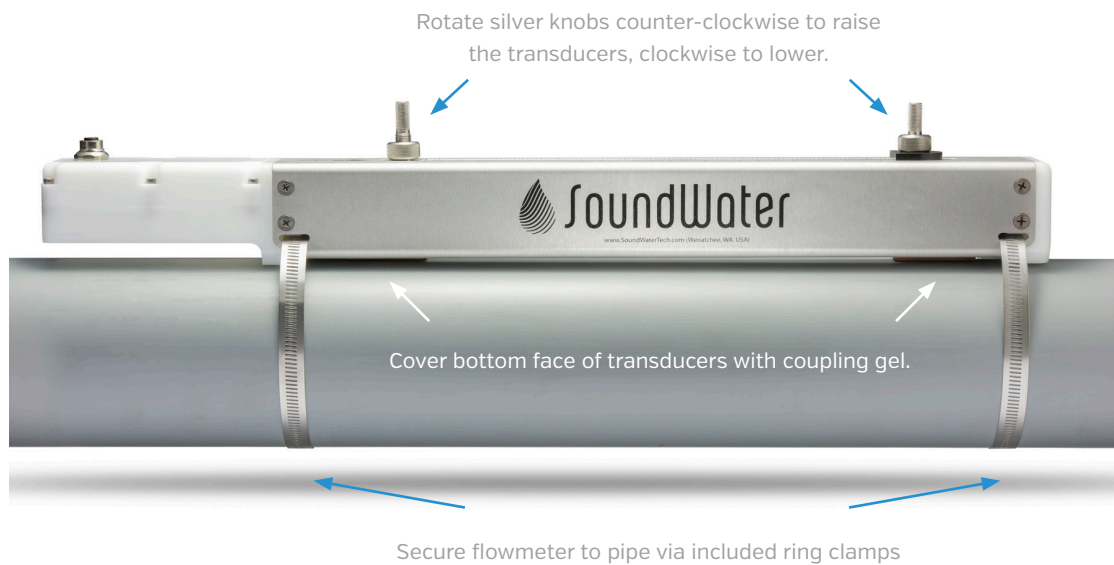

Do's and Don'ts

- Do** store your Orcas SP in a dry, inside area when not in use.
- Do** keep your Orcas SP in a protective case when transporting to prevent damage.
- Do** gently clean the transducer pads regularly with isopropyl alcohol to prevent hardening and build up of used coupling gel.
- Don't** store, transport, or use your Orcas SP where the device may exceed 150°F (65°C)
- Don't** bang or drop the Orcas SP on hard objects or surfaces.
- Don't** nick the transducer pads.

Operation

Collecting Your Data

Be sure the app is running on your mobile device and the flowmeter is plugged into a power source.

The app will display a list of all Orcas SP meters within its range. Tap the one you are currently using.

[Note: Your app will check the flowmeter to be sure it has the most recent programming. If there is a newer version available, it will give you the option of updating the meter. Updating the meter may take three to five minutes.]

Your flow data will display on the Orcas App.

When you are done collecting data, snap the cords out of their cam cleats and you are ready to move on to your next location. The next time you return to this location, the Orcas App will remember your settings.

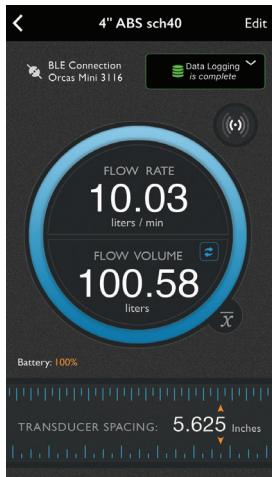
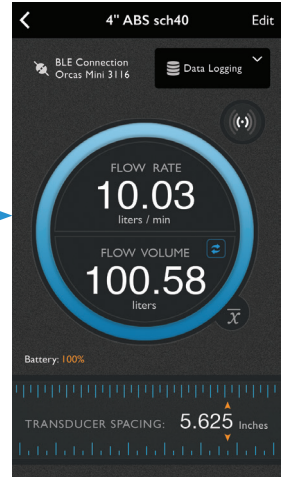

Data Logging

The purpose of the Orcas's built-in data logger is to record flow for a specified period of time. It may be used to conveniently record flow for as long as 14 days or as little as one minute. Orcas SP has limited memory. Thus, only one data log may be used at any one time. As the Orcas data logger uses Bluetooth [BLE] to transfer data from the flowmeter to the mobile device, data transfer speed is limited by BLE, which is not designed to transfer large data sets. Transferring the maximum sized data set will take up to 5 1/2 minutes.

All data logging functions are accessed by tapping the Data Logging button in the measurement view.



The Orcas's data logger stores only one data set at any time, selecting "Rec" [which creates a new data log] will write over the existing data log. A message appears when selecting the "Rec" button indicating that the existing data log will be over-written if a new data log is started and gives the user the ability to continue with the new data log or to cancel.

Making a Recording

- Connect to the meter with the Orcas App.
- Tap the Data Logging button to access the data logger features.
- Using the slider bar in the app's data logger setup view, set the recording time. [See Explanation of Recording Times on the next page.]
- Tap “Rec” to start the recording. Data will start recording on the meter. You can disconnect the mobile app during recording. The meter will turn off when done to save power, unless still connected to the app.
- To stop recording prior to completing the time period, connect the Orcas App to the meter, tap the Data Logging button, and tap “Stop.”

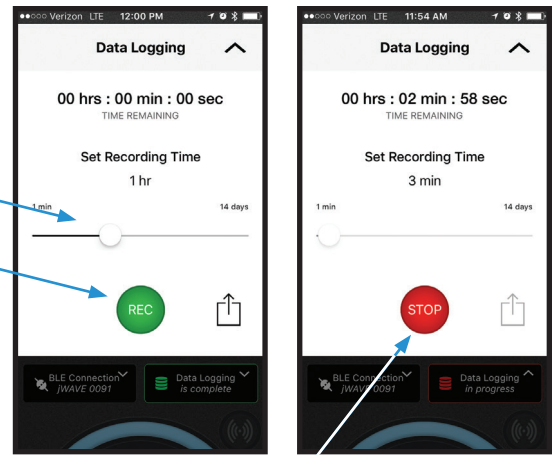

The status of the data logger is indicated by the color and text of the data logger setup button, located in the measurement view. If data logger is active, the button is outlined in red, shows a red disk drive, and displays the text “in progress.” If the data logger is completed, the button is outlined in green, shows a green disk drive, and displays the text “complete.” The data logger setup view also displays the remaining recording time for conveniently checking progress of data logging.

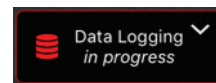

Active data logging session running.

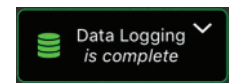

Data logging session complete.

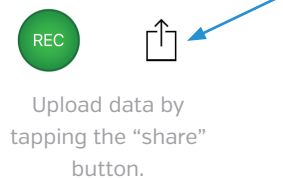

Upload data by tapping the “share” button.

Uploading Data

Data is stored on the flowmeter and may be retrieved at any time. To upload data, the data logger must be either complete or stopped and the app must be connected to the flowmeter. Data is uploaded using the “share” button located to the right of the “Rec” button. Uploading the maximum sized data set may take up to 5 1/2 minutes.

If you want to quickly review your data at any time, tap the “share” button, and then tap Quick Look. This displays the data log in a spreadsheet for immediate viewing on your mobile device.

Sharing Data

You only need to upload the data log once from Orcas. Once the data is uploaded, it may be shared any number of times without additional uploading, until a new data log is started. Tap the “share” button to share the data by a number of methods, email, text, AirDrop, etc. Shared data is formatted in a CSV file [comma delimited file]. The file name is unique and contains both the date and time that the data log was started as well as the location name. Setup information such as the date and time the data log was started, the number of samples, sampling period, and location name are located at the top of the data file. The data is arranged in rows, where each row contains a single flow measurement including sample number, time stamp, flow rate, velocity, volume, and quality. The data file can be viewed or printed as a text file or formatted using most spreadsheet and database programs, such as Microsoft® Excel or Access.

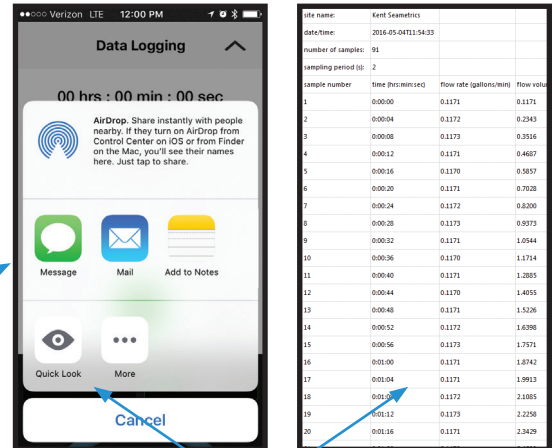

Tap “Quick Look” for immediate viewing of your data.



NOTE: The app must be connected to the Orcas SP in order to share the data or view it with Quick Look.

Explanation of Recording Times

The sampling rate (time between each recorded flow measurement) and total number of recorded measurements is controlled by the Orcas SP. The maximum possible number of flow measurements is 3750 and each includes five values-- flow rate, total, velocity, time stamp, and quality. The maximum sampling rate is two seconds.

The Orcas SP data logger will attempt to maximize the sampling rate, based on the your selected recording time. For example, if you select to record flow for one minute, then the Orcas SP maximizes the sampling rate at two seconds and will record 31 flow measurements (covering a total of 60 seconds).

If you select to record flow for four days, then the Orcas SP again attempts to maximize the number of flow measurements; however since there is not enough memory to record flow every two seconds for four days, it configures the sampling period to maximize the number of flow measurements. For the case of four days, the Orcas SP sets the sampling period at 92 seconds giving you over 3500 flow measurements.

Length	Sample Period
1 minute	2 seconds
1 hour	2 seconds
10 hours	9 seconds
1 day	23 seconds
4 days	92 seconds (1 min. 32 sec.)
10 days	230 seconds (3 min. 50 sec.)
14 days	322 seconds (5 min. 22 sec.)

Troubleshooting

Problem	Probable Causes	Things to try...
Continuously displays “Analyzing Flow”	<p>Incorrect setup</p> <p>Air in pipe</p> <p>Internal rust or corrosion on pipe</p>	<p>Confirm pipe settings</p> <p>Rotate meter to 3 o’clock position</p> <p>Remove air</p> <p>Relocate meter to another location where there is no air</p> <p>Relocate meter to clean section of pipe. If no clean section is available, move meter to other locations until a signal is found—try to find a section of pipe with less corrosion or rust.</p>
Orcas App not displaying any flowmeters to connect	<p>Bluetooth not enabled</p> <p>Mobile device not Bluetooth 4.0+, LE (Low Energy).</p>	<p>Open your iOS or Android system settings App and enable Bluetooth. Close, and relaunch the Orcas App.</p> <p>Orcas App is compatible only with Bluetooth 4.0 (or later), also known as Bluetooth LE, or Bluetooth Low Energy. Most mobile devices are BLE enabled; however some older devices may use standard Bluetooth and may not be compatible.</p>



1-509-899-7838



support@soundwatertech.com



soundwatertech.com